

Sistema a parete  
Wall system

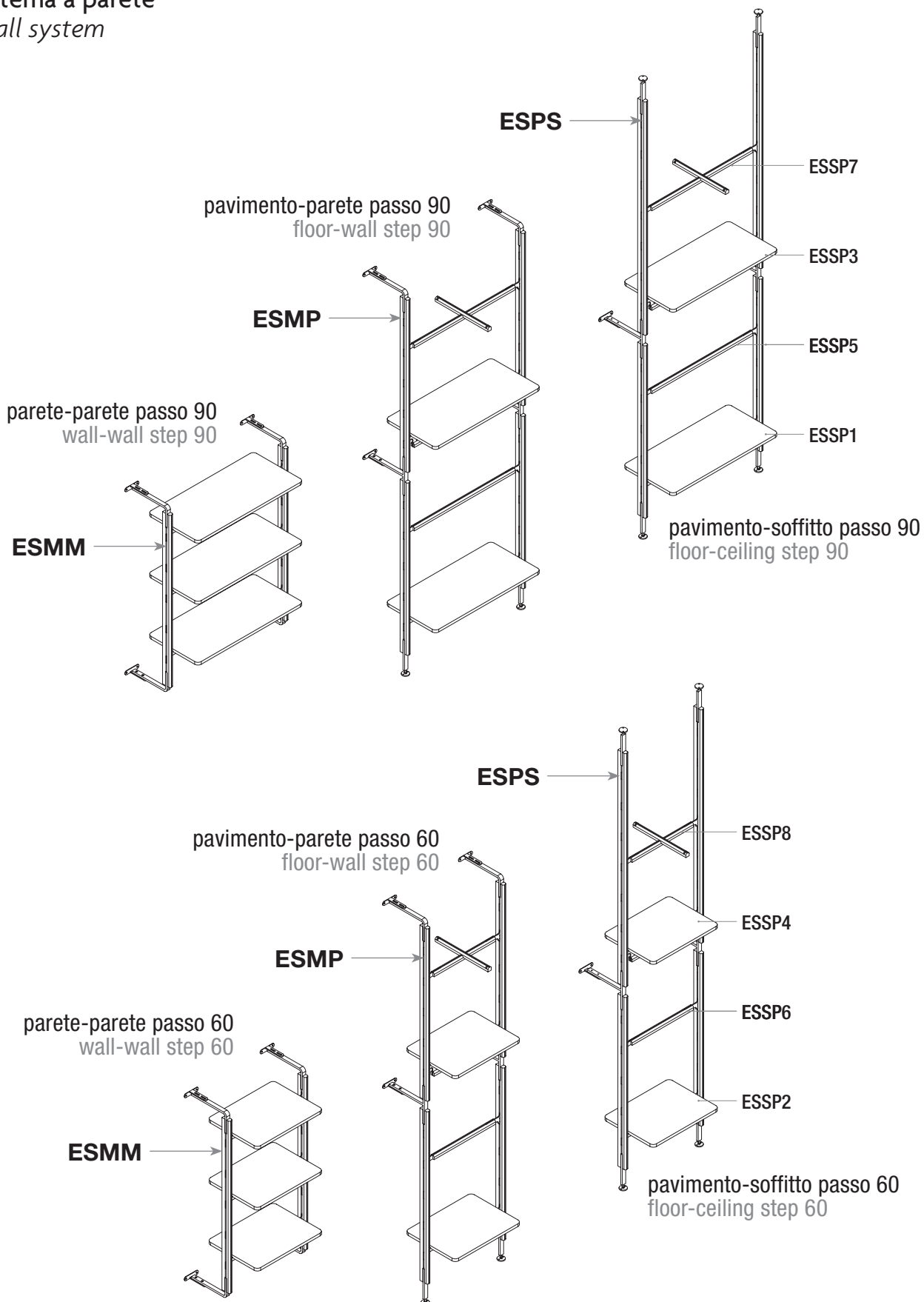

.....

## Dimensioni sistema a parete

Wall system dimensions

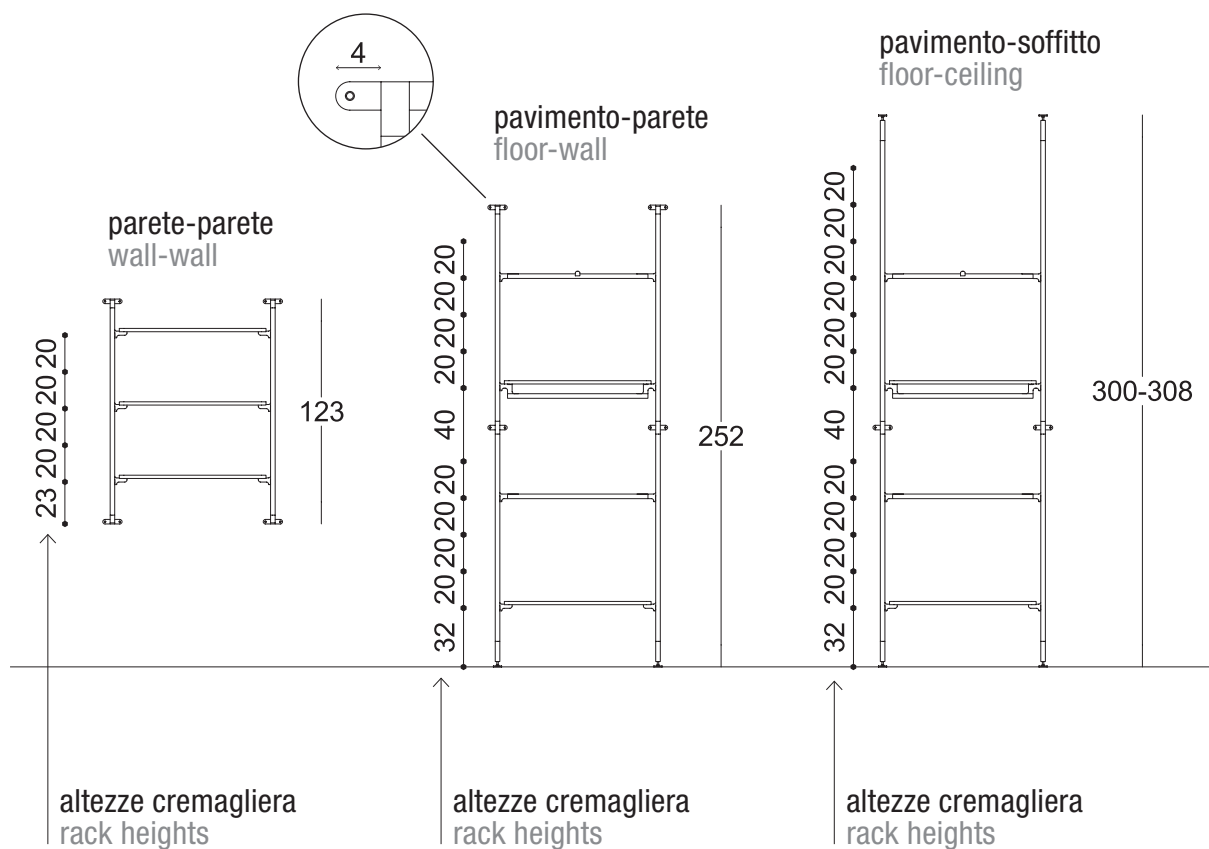
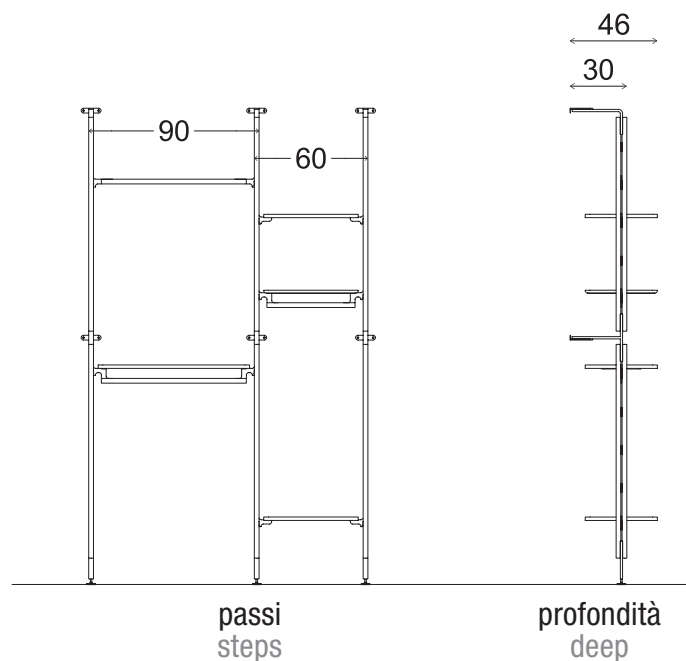

Accessori per sistema a parete  
*Wall system accessories*

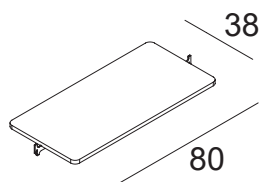

**ESSP1**

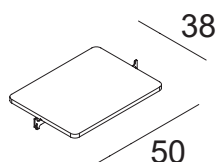

**ESSP2**

mensola in nobilitato  
 con staffe in metallo  
 chipboard shelf  
 with metal bracket

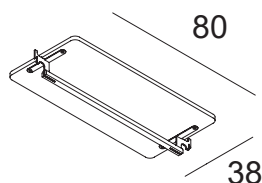

**ESSP3**

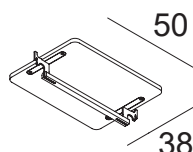

**ESSP4**

mensola in nobilitato con barra  
 appenderia in legno e staffe in metallo  
 chipboard shelf with wood hanging bar  
 and metal bracket



**ESSP5**



**ESSP6**

barra appenderia in legno  
 con staffe in metallo  
 wood hanging bar  
 with metal bracket

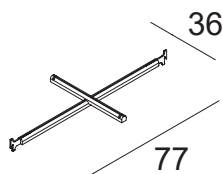

**ESSP7**

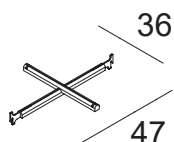

**ESSP8**

barra appenderia frontale in  
 legno con staffe in metallo  
 wood frontal hanging bar  
 with metal bracket

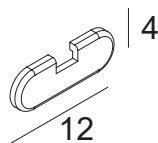
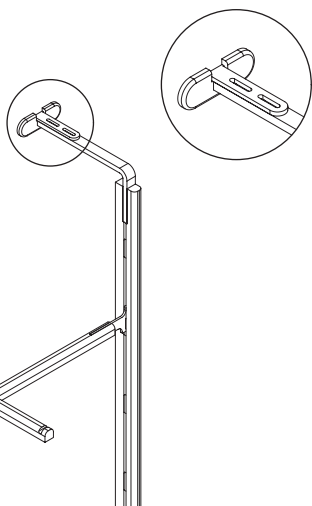

**ESCOV**

cover copri-staffa  
 calamitata in legno  
 magnetized wooden  
 cover for bracket

Regolazioni in altezza e profondità  
*Adjustable in height and depth*

